

NO	NAME	DATE	SIGN

REV	REVISION	DATE	SIGN

132KV CTG, VTG & CVT
 SK NO 08409/1A
 SHEET 3A

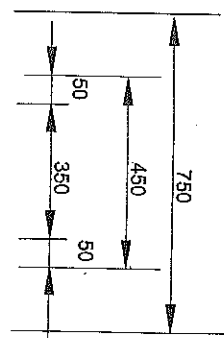
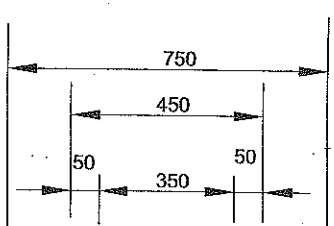
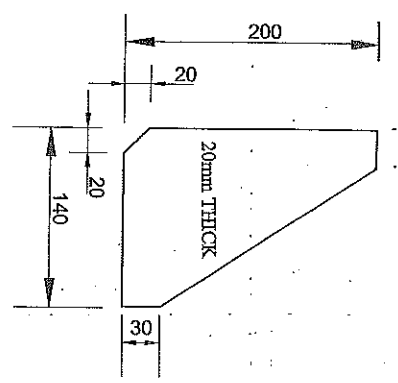
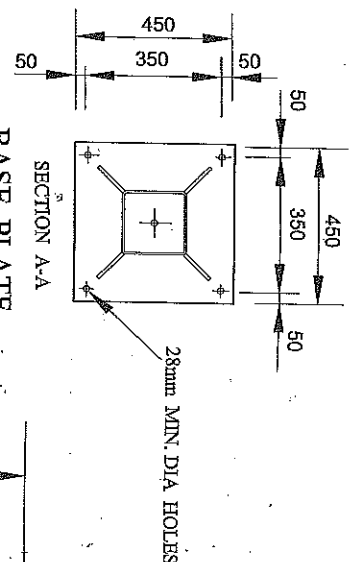
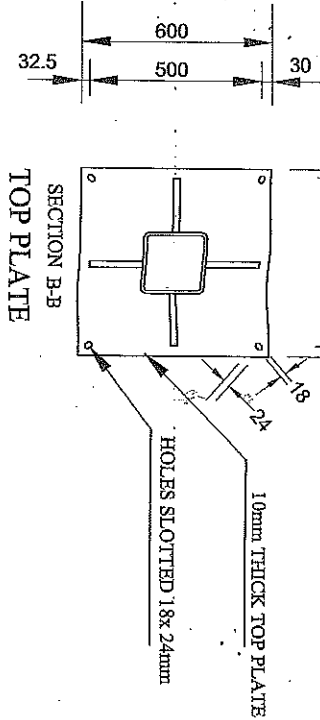
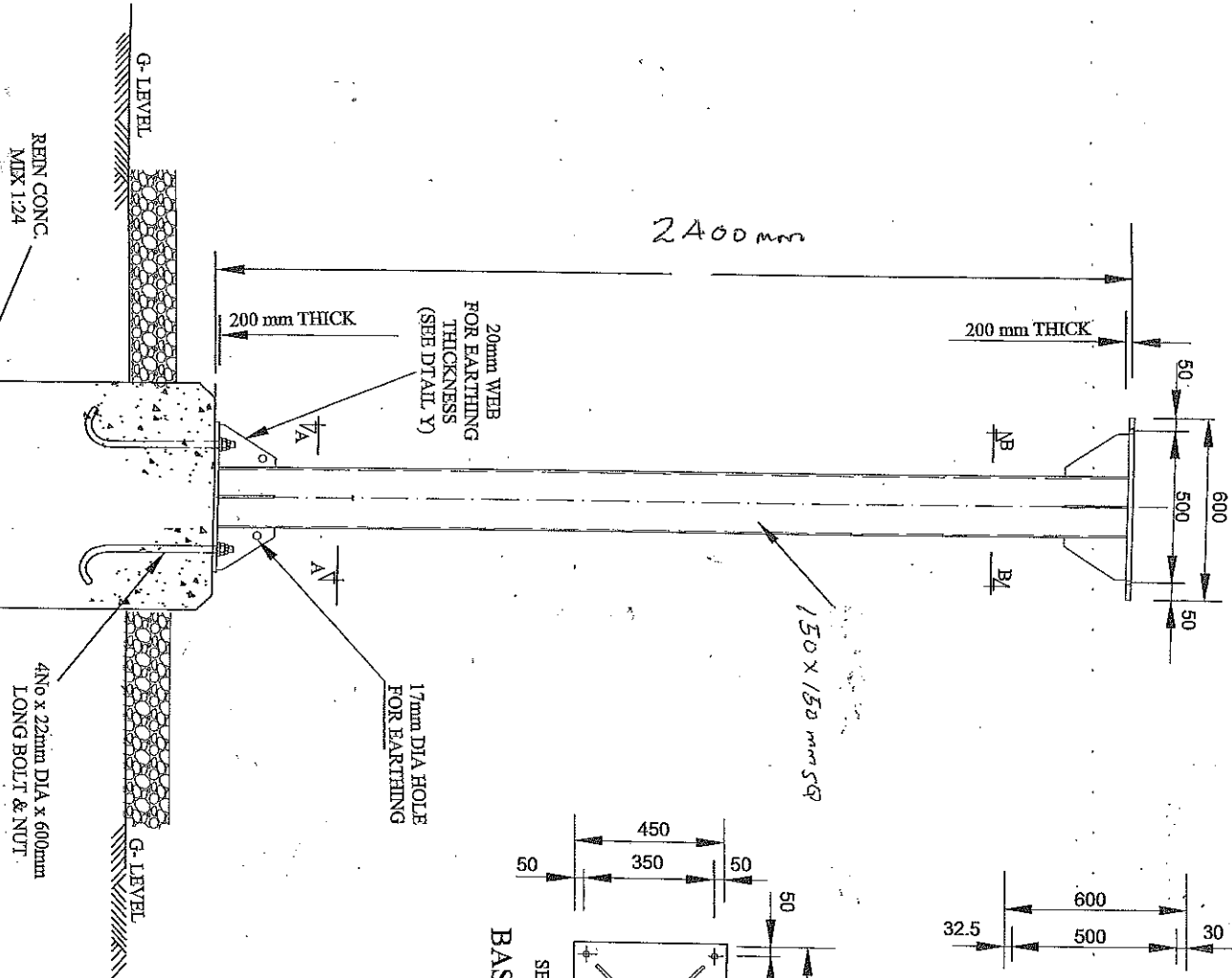

- NOTES :-
1. ALL MATERIALS TO BE MILD STEEL TO BSS 4360
 2. ALL STEEL WORK TO BE FREE FROM RUST DIRT BURRS ETC AND THEN GALVANIZED BY HOT DIP PROCESS THICKNESS AND QUALITY OF ZINC COATING TO WITHSTAND TESTS OF BSS 729.
 3. EQUIPMENT CONNECTING BOLTS NUTS AND WASHERS TO BE SUPPLIED BY THE MANUFACTURERS.
 4. BOLT THREADS TO BE RECUT WITH SLACK DIES AFTER GALVANIZING AND THEN GREASED.
 5. SUPPLIED BOLTS NUTS AND WASHERS TO INCLUDE 10% SPARE AND TO CONFORM TO TO BSS 916
 6. FABRICATORS ARE TO DESIGNATE ALL STEEL WORK ITEM AS PER THIS DRAWING AND ARE TO PROVIDE REJECTION MARK.

4 No 25mm dia x 600 mm
 LONG BOLTS WITH FLAT
 NUTS & LOCK NUTS